



**Connect Tech Inc.**

*“Industrial Strength Communications”*

---

## **Intellicon-NT960/PCI**

### **Intelligent Serial Communications Subsystem**

### **User Manual**

**Connect Tech Inc**

**42 Arrow Road**

**Guelph, Ontario**

**N1K 1S6**

**Tel: 519-836-1291**

**800-426-8979**

**Fax: 519-836-4878**

**Email: [sales@connecttech.com](mailto:sales@connecttech.com)**

**URL: <http://www.connecttech.com>**

**CTIM-00008, Revision 0.02, January 7 2003**

**Part Number: MAN062**



---

## LIMITED WARRANTY

Connect Tech Inc. provides a Lifetime Warranty for all Connect Tech Inc. products. Should this product, in Connect Tech Inc.'s opinion, fail to be in good working order during the warranty period, Connect Tech Inc. will, at its option, repair or replace this product at no charge, provided that the product has not been subjected to abuse, misuse, accident, disaster or non Connect Tech Inc. authorized modification or repair.

You may obtain warranty service by delivering this product to an authorized Connect Tech Inc. business partner or to Connect Tech Inc. along with proof of purchase. Product returned to Connect Tech Inc. must be pre-authorized by Connect Tech Inc. With an RMA (Return Material Authorization) number marked on the outside of the package and sent prepaid, insured and packaged for safe shipment. Connect Tech Inc. will return this product by prepaid ground shipment service.

The Connect Tech Inc. Lifetime Warranty is defined as the serviceable life of the product. This is defined as the period during which all components are available. Should the product prove to be irreparable, Connect Tech Inc. reserves the right to substitute an equivalent product if available or to retract Life Time Warranty if no replacement is available.

The above warranty is the only warranty authorized by Connect Tech Inc. Under no circumstances will connect tech inc. be liable in any way for any damages, including any lost profits, lost savings or other incidental or consequential damages arising out of the use of, or inability to use, such product.

## **Copyright Notice**

The information contained in this document is subject to change without notice. Connect Tech shall not be liable for errors contained herein or for incidental consequential damages in connection with the furnishing, performance, or use of this material. This document contains proprietary information which is protected by copyright. All rights are reserved. No part of this document may be photocopied, reproduced, or translated to another language without the prior written consent of Connect Tech, Inc.

Copyright © 2001, 2002 by Connect Tech, Inc.

## **Trademark Acknowledgment**

Connect Tech, Inc. acknowledges all trademarks, registered trademarks and/or copyrights referred to in this document as the property of their respective owners.

Not listing all possible trademarks or copyright acknowledgments does not constitute a lack of acknowledgment to the rightful owners of the trademarks and copyrights mentioned in this document.

---

## CLASS A COMPUTING DEVICE

### Intellicon-NT960/PCI, ACM/16, ACM/Flex16, ACM/16RJ

#### FCC

This equipment complies with the requirements in Part 15 of FCC Rules for a Class A computing device. Operation of this equipment in a residential area may cause unacceptable interference to radio and TV reception requiring the operator to take whatever steps are necessary to correct the interference.

#### DOC/IC

This Class A digital apparatus meets all the requirements of the Canadian Interference-Causing Equipment Regulations as defined in ICES-003.

Cet appareil numérique de la classe A respecte toutes les exigences du Règlement sur le matériel brouiller du Canada.

#### General

The above agency conformance were met by independent laboratory testing of Connect Tech Inc. product(s) with shielded cables, with metal hoods, attached to either the terminating connectors or cable assemblies supplied with the product(s).

**Failure to follow good EMC/EMI compliant cabling practices may produce more emissions or less immunity than were obtained in laboratory measurements.**

Operation of this equipment in a residential area may cause unacceptable interference to radio a TV reception, requiring the user to take whatever steps necessary to correct the interference.



# Table of Contents

## Chapter 1: Introduction

Introduction .....	1-1
Manual Overview .....	1-2
Conventions & Symbols .....	1-3
Product Overview .....	1-4
Intellicon-NT960/PCI Host Adapter .....	1-4
Intellicon-NT960/PCI ACM/16 .....	1-5
Intellicon-NT960/PCI ACM/16RJ .....	1-7
Intellicon-NT960/PCI ACM/Flex16 .....	1-9
Intellicon-NT960/PCI Software .....	1-12
Customer Service Overview .....	1-12
RMA Overview.....	1-15

## Chapter 2: Hardware Installation

Introduction .....	2-1
NT960/PCI Host Adapter.....	2-1
Installing the NT960/PCI in your System.....	2-2
ACM/16, ACM/16RJ and ACM/Flex16 .....	2-2
ACM/16/16RJ/Flex16 Address Selection.....	2-3
SLIM Installation(ACM/Flex16).....	2-6
SLIM Options.....	2-8
LED interface indicators (ACM/Flex16).....	2-8
ACM/16/16RJ/Flex16 to NT960/PCI Host Adapter.....	2-9

## Chapter 3: Software Installation

Introduction .....	3-1
--------------------	-----

## Chapter 4: Appendices

Appendix A: Specifications .....	4-1
NT960/PCI Host Adapter.....	4-1
Processor .....	4-1
Memory .....	4-1
PCI Bus Interface .....	4-1
Operating Environment .....	4-1
Power Requirements.....	4-1
Dimensions.....	4-1
NT960/PCI ACM/16, ACM/16RJ, ACM/Flex16.....	4-1
Asynchronous Communication Module .....	4-1
Operating Environment .....	4-2
Power Requirements.....	4-2
Dimensions.....	4-2
NT960/PCI Part Numbers.....	4-3
Certification .....	4-4
Intellicon-NT960/PCI; ACM/16/Flex16/16RJ .....	4-4
FCC .....	4-4
DOC/IC .....	4-4
General .....	4-4
Appendix B: Connector Pinouts .....	4-5
ACM/16 Pinouts .....	4-5
ACM/Flex16 Pinouts .....	4-6
ACM/Flex16 SLIM Pinouts.....	4-6
ACM/16RJ Pinouts .....	4-9
Appendix C: RS-232 Option .....	4-10
Installation .....	4-11
LED interface indicators .....	4-11
Appendix D: RS-485/422 Option .....	4-12
Introduction.....	4-12
Installation .....	4-14
LED interface indicators .....	4-14
Configuration options .....	4-15
Line bias feature .....	4-17
Line load options .....	4-17
RS-485/422 Cable Wiring.....	4-20
Appendix E: 20mA Current Loop Option .....	4-22
Installation .....	4-23
LED interface indicators .....	4-23
20mA Current Loop.....	4-24
Current Loop Cable Wiring .....	4-25



**Chapter 4: Appendices (continued)**

Appendix F: SLIM Insertion/Removal .....	4-26
ACM/Flex16 back cover removal .....	4-27
SLIM insertion .....	4-28
SLIM removal .....	4-29
Appendix G: Factory Settings .....	4-30
NT960/PCI Host Adapter.....	4-30
ACM/16, ACM/Flex16, ACM/16RJ Modules .....	4-31
ACM/16, ACM/Flex16, ACM/16RJ Address Setting .....	4-31
ACM/Flex16: RS-485 SLIM options .....	4-34

**List of Tables**

Table 1: ACM/16/Flex16/16RJ address settings .....	2-5
Table 2: NT960/PCI SW1 switch settings .....	2-10
Table 3: DB-9 pinouts - ACM/16.....	4-5
Table 4: DB-9 pinouts - ACM/Flex16.....	4-6
Table 5: ACM/Flex16 SLIM pinouts.....	4-7
Table 5(continued): ACM/Flex16 SLIM pinouts .....	4-8
Table 6: RJ-45 pinouts - ACM/16RJ .....	4-9
Table 7: RS-485/422 SLIM; port/switch block relation .....	4-16
Table 8: RS-485/422 SLIM; line load options.....	4-16
Table 9: NT960/PCI SW1 factory settings .....	4-30

## List of Figures

Figure 1: NT960/PCI Host Adapter.....	1-5
Figure 2: ACM/16 module .....	1-6
Figure 3: ACM/16RJ module .....	1-8
Figure 4: ACM/Flex16 module .....	1-10
Figure 5: Intellicon-NT960/PCI - 32 port configuration.....	1-11
Figure 6: Problem summary sheet .....	1-13
Figure 7: ACM/16/Flex16 address switch block .....	2-3
Figure 8: ACM/16RJ address switch block .....	2-4
Figure 9: ACM/Flex16: SLIM socket locations .....	2-6
Figure 10: LED interface indicators (ACM/Flex16).....	2-9
Figure 11: Connection of one ACM/16/16RJ/Flex16 module .....	2-13
Figure 12: Connection of three ACM/16/16RJ/Flex16 modules .....	2-14
Figure 13: Connection of six ACM/16/16RJ/Flex16 modules.....	2-15
Figure 14: RS-232 SLIM partial schematic .....	4-10
Figure 15: RS-485/422 SLIM partial schematic .....	4-13
Figure 16: RS-485/422 SLIM - DIP switches.....	4-15
Figure 17: Typical RS-485 circuit .....	4-17
Figure 18: RS-485/422 wiring diagram(8 wire) .....	4-20
Figure 19: RS-485/422 wiring diagram(4 wire) .....	4-20
Figure 20: RS-485/422 wiring diagram(2 wire) .....	4-21
Figure 21: 20mA Current Loop partial schematic .....	4-22
Figure 22: Current Loop wiring diagram(4 wire) .....	4-25
Figure 23: ACM/Flex16 back cover removal .....	4-27
Figure 24: SLIM insertion (ACM/Flex16) .....	4-28
Figure 25: SLIM removal (ACM/Flex16) .....	4-29
Figure 26: ACM/16, ACM/Flex16 factory settings .....	4-32
Figure 27: ACM/16RJ factory setting .....	4-33
Figure 28: ACM/Flex16 RS-485 SLIM settings.....	4-34

# Chapter 1: Introduction

---

- Introduction ..... 1-1
- Manual Overview ..... 1-2
  - Conventions & Symbols ..... 1-3
- Product Overview ..... 1-4
  - Intellicon-NT960/PCI Host Adapter ..... 1-4
  - Intellicon-NT960/PCI ACM/16 ..... 1-5
  - Intellicon-NT960/PCI ACM/16RJ ..... 1-7
  - Intellicon-NT960/PCI ACM/Flex16 ..... 1-9
  - Intellicon-NT960/PCI Software ..... 1-12
- Customer Service Overview ..... 1-12
  - RMA Overview..... 1-15



## Introduction

This section contains an overall description of the Intellicon-NT960/PCI manual, the Intellicon-NT960/PCI product, Connect Tech technical services, Return Merchandise Authorization and warranty repair policies. The organization of the information is as follows:

- Manual Overview - describes the structure of the manual and the conventions the manual uses.
- Product Overview - describes the Intellicon-NT960/PCI, its features and specifications.
- Customer Services Overview - describes the various customer support services available to users of Connect Tech products.
- RMA Overview - describes the RMA policy and procedures for all Connect Tech products.

## Manual Overview

The purpose of the Intellicon-NT960/PCI User's Manual is to help you install the Intellicon-NT960/PCI subsystem as effortlessly as possible. The manual includes four main sections:

- Introduction - the section you are currently reading, covers the Intellicon-NT960/PCI features; Connect Tech's customer services; and return merchandise authorization (RMA) policies and procedures.
- Hardware Installation - describes installation of the Intellicon-NT960/PCI host adapter and the Intellicon-NT960/PCI ACM/16, ACM/16RJ and ACM/Flex16 external modules.
- Software Installation - discusses the installation of the Intellicon-NT960/PCI device drivers under various operating systems.

**Note:**

*We recommend that you read both the **Hardware Installation** and **Software Installation** sections before you attempt to install the Intellicon-NT960/PCI.*

- Appendices - the appendices contain information on electrical pinouts, product specifications such as power requirements; and other technical information.

## Conventions & Symbols

This manual uses the following conventions:

- In most cases the font for file names and command statements is 9 point Arial Narrow Bold. An example is:

**DEVICE=NT960.SYS a=D000 p=300 n=1 i=3 d=COM**

- *Note: the "Note" convention informs you of important messages, exceptions, or special cases.*

- *Example: the "Example" convention outlines hardware and software installation examples.*

- *Technical Tip: the "Technical Tip" convention offers technical tips to assist you in hardware and software installation or problems.*

## WARNING

*The "Warning" convention advises you to take certain precautions in order to avoid possible damage to your Connect Tech product.*



*This message warns you that your Connect Tech product is very sensitive to static electricity. Make sure that before you handle the product you practice proper ESD procedures.*

**Product Overview**

The Intellicon-NT960/PCI is a high performance intelligent multi-port subsystem that allows you to connect up to 128 serial devices through one expansion slot.

The Intellicon-NT960/PCI subsystem consists of the following components:

- Intellicon-NT960/PCI Host Adapter
- Intellicon-NT960/PCI ACM/16, ACM/16RJ or ACM/Flex16, power supply, and bus cable
- Intellicon-NT960/PCI Device Drivers

**Intellicon-NT960/PCI Host Adapter**

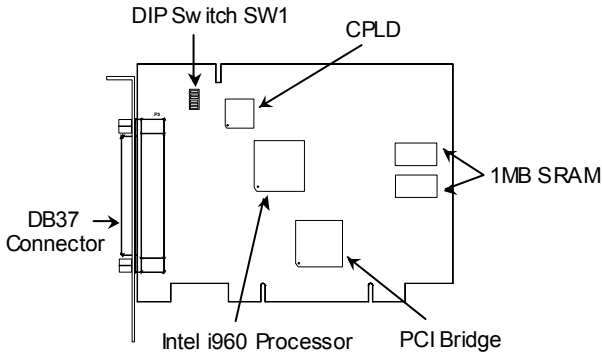
The NT960/PCI Host Adapter provides the high-speed interface between a host computer and an external ACM/16, ACM/16RJ or ACM/Flex16 communication module. The NT960/PCI Host Adapter off loads from the host computer the task of managing the serial communication component of an application. The Intellicon-NT960/PCI Host Adapter includes features such as:

- Connects up to eight ACM/16, ACM/16RJ and/or ACM/Flex16 modules giving you a total of 128 asynchronous RS-232 and/or RS-485/422 and/or 20mA Current Loop serial ports out of one slot.
- 1MB of dual ported SRAM for data and program storage.
- System requirements are one 3.3V, 5V or universal PCI bus compatible expansion slot; one available interrupt, one available 2MB memory segment which is assigned by the Plug and Play system.



**Figure 1** shows the locations of various hardware components of the NT960/PCI Host Adapter.

**Figure 1:** *NT960/PCI Host Adapter*



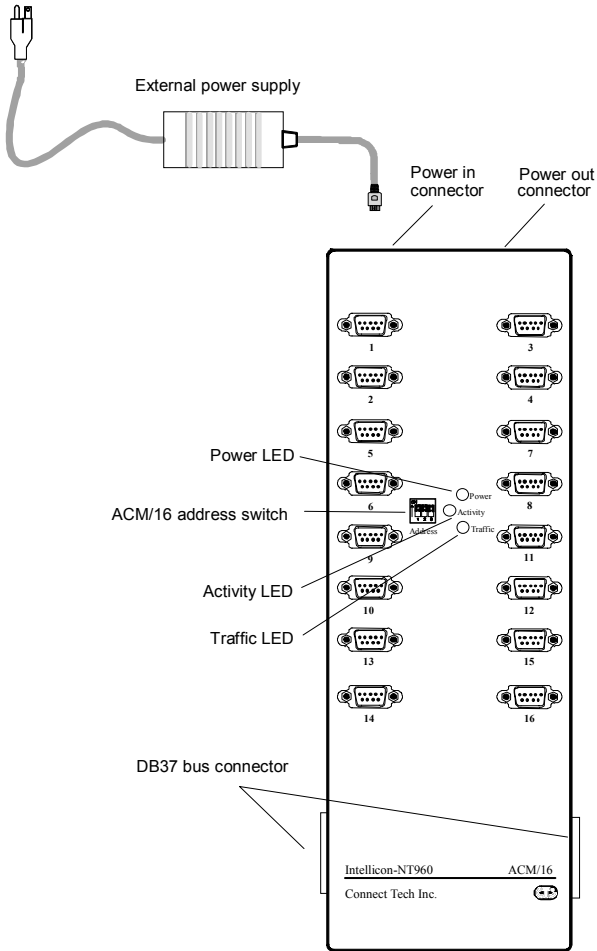
### Intellicon-NT960/PCI ACM/16

The ACM/16 (Asynchronous Communication Module) is an external module that connects to the NT960/PCI Host Adapter via a high speed 37 pin external bus cable. **Figure 2** shows a top view of the ACM/16. The ACM/16 offers the following features:

- 16 asynchronous RS-232-C serial ports.
- Four CLCD1400 RISC-like quad UARTS c/w 12 bytes of receive and 12 bytes of transmit FIFO for each port.
- Each port is individually programmable for baud rates up to 115 Kbps.
- Each RS-232 port supports the following signals: TxD, RxD, DTR, DSR, RTS, CTS, DCD, RI.
- Support for 5 to 8 data bits per character plus optional parity; odd, even, no or forced parity; and 1 or 2 Stop Bits.
- Includes a 37 pin bus cable and an external power supply.

- Up to eight ACM/16's, ACM/16RJ's and/or ACM/Flex16's can connect to an Intellicon-NT960/PCI Host Adapter providing up to 128 serial ports.

**Figure 2:** ACM/16 module

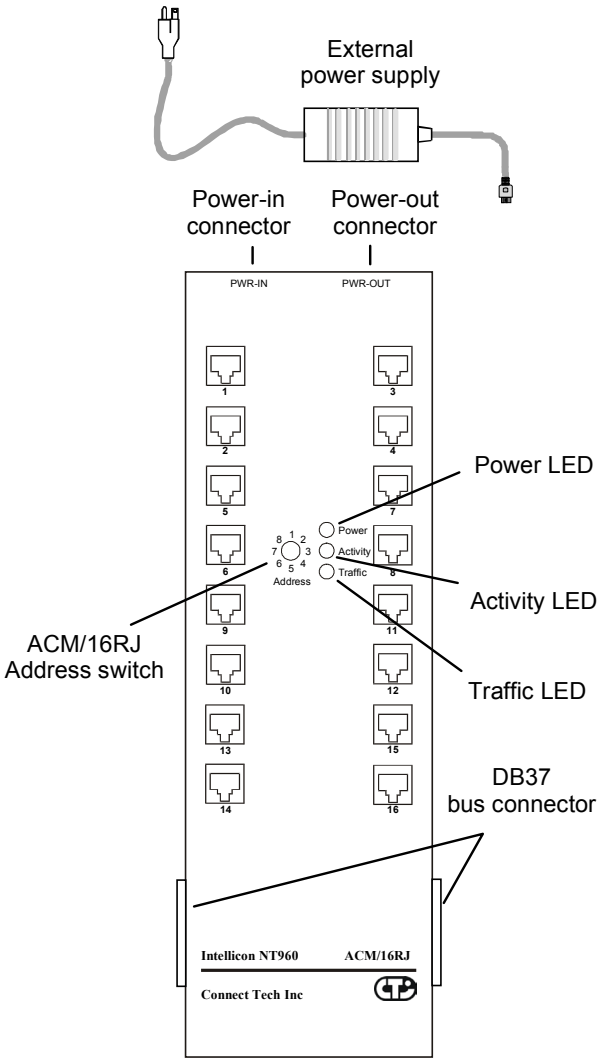


**Intellicon-NT960/PCI ACM/16RJ**

The ACM/16RJ (Asynchronous Communication Module) is an external module that connects to the NT960/PCI Host Adapter via a high speed 37 pin external bus cable. **Figure 3** shows a top view of the ACM/16RJ. The ACM/16RJ offers the following features:

- 16 asynchronous RS-232-C serial ports
- 16 RJ-45 (8 pin) connectors
- Four CLCD1400 RISC-like quad UARTS c/w 12 bytes of receive and 12 bytes of transmit FIFO for each port.
- Each port is individually programmable for baud rates up to 115 Kbps.
- Each RS-232 port supports the following signals: TxD, RxD, DTR, RTS, CTS, DCD.
- Support for 5 to 8 data bits per character plus optional parity; odd, even, no or forced parity; and 1 or 2 Stop Bits.
- Includes a 37 pin bus cable and an external power supply.
- Up to eight ACM/16's, ACM/16RJ's and/or ACM/Flex16's can connect to an Intellicon-NT960/PCI Host Adapter providing up to 128 serial ports.

**Figure 3:** ACM/16RJ module



**Intellicon-NT960/PCI ACM/Flex16**

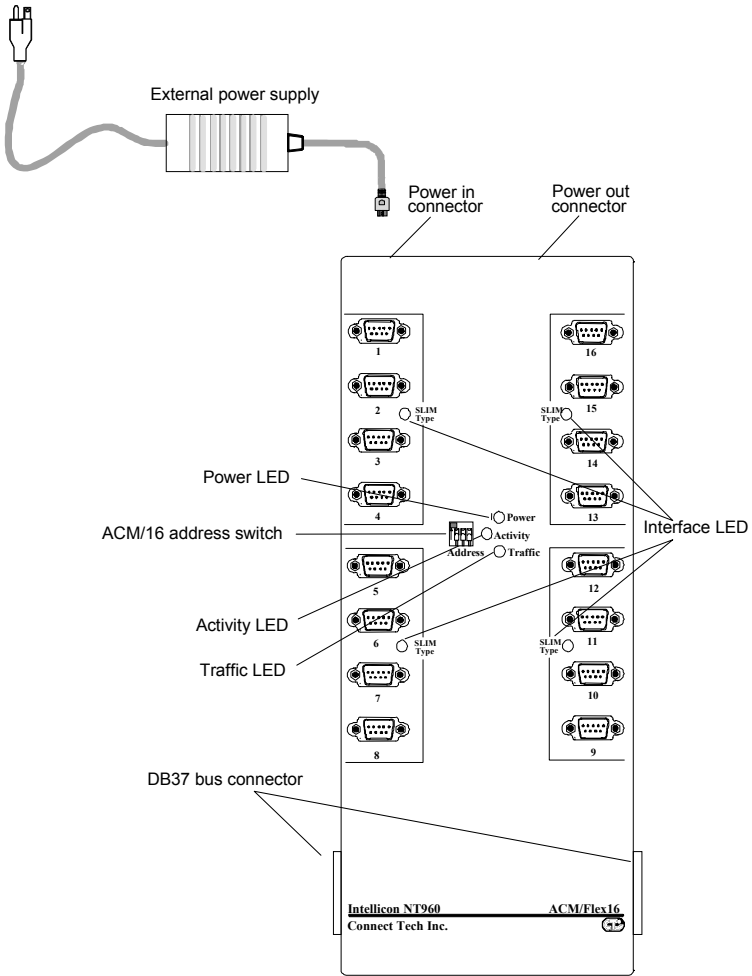
The ACM/Flex16 (Asynchronous Communication Module) is an external module that connects to the NT960/PCI Host Adapter via a high speed 37 pin external bus cable. **Figure 4** shows a top view of the ACM/Flex16. The ACM/Flex16 offers the following features:

- 16 asynchronous RS-232-C and/or RS-485/422 and/or 20mA Current Loop serial ports
- The RS-232, RS-485/422 and 20mA Current Loop electrical interfaces are on field upgradeable Serial Line Interface Modules (SLIM). This allows you to run different line interfaces on the ACM/Flex16 at the same time.
- Four CLCD1400 RISC-like quad UARTS c/w 12 bytes of receive and 12 bytes of transmit FIFO for each port.
- Each port is individually programmable for baud rates up to 115 Kbps.
- Each RS-232 port supports the following signals: TxD, RxD, DTR, DSR, RTS, CTS, DCD, RI.

***Note:** ports 3, 4, 7, 8, 11, 12, 15 and 16 do not support the RI signal.*

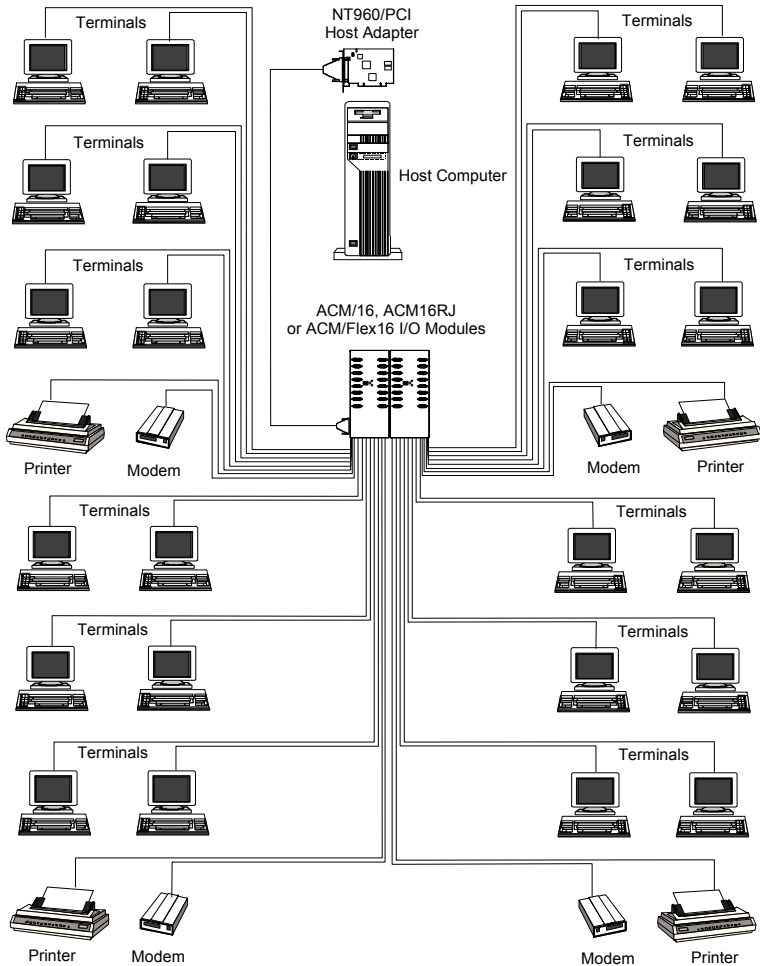
- Each RS-485/422 port supports the following signals: TxD, RxD, RTS, CTS.
- Each 20mA Current Loop port supports the following signals: TxD, RxD.
- Support for 5 to 8 data bits per character plus optional parity; odd, even, no or forced parity; and 1 or 2 Stop Bits.
- Includes a 37 pin bus cable and an external power supply.
- Up to eight ACM/16's, ACM/16RJ's and/or ACM/Flex16's can connect to an Intellicon-NT960/PCI Host Adapter providing up to 128 serial ports.

**Figure 4:** *ACM/Flex16 module*



The Intellicon-NT960/PCI subsystem can accommodate both small and large multi-channel applications. The NT960/PCI Host Adapter can connect up to eight ACM/16, ACM/16RJ and/or ACM/Flex16 modules for a total of 128 ports. **Figure 5** below represents a sample configuration for a system requiring 32 ports.

**Figure 5:** *Intellicon-NT960/PCI - 32 port configuration*



**Intellicon-NT960/PCI Software**

The NT960/PCI ships with software device drivers. These device drivers provide support for multi-port serial communications with different operating systems without the need for programming.

See **Chapter 3: Software Installation** for driver installation instructions for the different operating systems.

**Customer Service Overview**

If you experience difficulties after reading the manual and using the product, contact the Connect Tech reseller from which you purchased the product. In most cases the reseller can help you with product installation and difficulties.

In the event that the reseller is unable to resolve your problem, our highly qualified support staff can assist you. Please refer to and complete the problem summary sheet found in **Figure 6** before contacting us.



**Figure 6:** *Problem summary sheet*

<b>Problem Description</b>	
<b>Connect Tech Product Description</b>	
Product:	Revision no.:
Product serial no.:	No. of serial ports:
IRQ selected:	Base address selected:
I/O port address selected:	
Device driver:	Revision no.:
<b>System Description</b>	
Operating system:	Revision no.:
System type & manufacturer:	
Amount of RAM:	CPU type/speed:
Video adapter:	Settings:
Network adapter:	Settings:
Hard disk adapter:	Settings:
Tape adapter:	Settings:
Other serial adapters	Settings:
Other adapters:	Settings:
Devices connected to ports:	

We offer several ways for you to contact us:

**Mail/Courier**

You may contact us by letter and our mailing address for correspondence is:

Connect Tech Inc.  
c/o Customer Service  
42 Arrow Road  
Guelph, Ontario  
Canada N1K 1S6

**Email/Internet**

You may contact us through the Internet. Our email and URL addresses on the Internet are:

[sales@connecttech.com](mailto:sales@connecttech.com)  
[support@connecttech.com](mailto:support@connecttech.com)  
[www.connecttech.com](http://www.connecttech.com)

**Note:**

1. *You can submit your technical support questions to our customer support engineers via our Internet email address  
OR*
2. *You can refer to our knowledge database found in the Customer Support section of our World Wide Web site.  
OR*
3. *You can fill out the problem summary form, found in the Customer Support section of our World Wide Web site and submit it to our customer support engineers via the Web.  
OR*
4. *You can obtain the latest versions of software drivers and manuals from the Customer Support section of our World Wide Web site.*

**Telephone/Facsimile**

Customer Support representatives are ready to answer your call Monday through Friday, from 9:00 a.m. to noon and 1:00 p.m. to 5:00 p.m. Eastern Standard Time. Our numbers for calls are:

Telephone: 519-836-1291  
Toll free: 800-426-8979  
Facsimile 519-836-4878 (on-line 24 hours)

## RMA Overview

Connect Tech products requiring warranty or non warranty repairs need an RMA number. To obtain a Return Merchandise Authorization (RMA) Number please contact us in the following manner:

- Go to the **RMA Request Form** found in the **Support Center** on our website:

[www.connecttech.com](http://www.connecttech.com)

- Telephone, fax, email or mail us at:

Connect Tech Inc.  
Technical Support  
42 Arrow Road  
Guelph, Ontario  
Canada N1K 1S6

Phone: 519-836-1291  
800-426-8979

Facsimile: 519-836-4878

Email: [support@connecttech.com](mailto:support@connecttech.com)

Include with the product, proof of purchase (including date of purchase), a description of the problem and the RMA number. Clearly display the RMA number on the external packaging. Please refer to the Limited Warranty for further restrictions or requirements.



**ATTENTION**  
**Contents**  
**Static Sensitive**

*The NT960/PCI Host Adapter is very sensitive to static electricity. Make sure that before you remove the card from your computer, you wear an anti-static wristband. When you remove the board from your computer, handle it only by the edges and place it on the anti-static bag or an anti-static mat.*

**Note:**

1. Please pack the item for repair securely and ship it **prepaid and insured**. **Connect Tech is not liable for damage or loss to the product due to shipping.**
2. Connect Tech will not accept items for repair without an RMA number.
3. Connect Tech will not accept items for repair shipped freight collect.



# Chapter 2: Hardware Installation

---

- Introduction ..... 2-1
  - NT960/PCI Host Adapter ..... 2-1
    - Installing the NT960/PCI in your System ..... 2-2
  - ACM/16, ACM/16RJ and ACM/Flex16 ..... 2-2
    - ACM/16/16RJ/Flex16 Address Selection ..... 2-3
    - SLIM Installation(ACM/Flex16) ..... 2-6
    - SLIM Options ..... 2-8
    - LED interface indicators (ACM/Flex16) ..... 2-8
    - ACM/16/16RJ/Flex16 to NT960/PCI Host Adapter ..... 2-9



## Introduction

Hardware installation involves configuration of the following:

- The NT960/PCI Host Adapter
- One or more ACM/16, ACM/16RJ or ACM/Flex16 external modules

### NT960/PCI Host Adapter

Installation of the NT960/PCI Host Adapter consists of:

1. Installing the Host Adapter in your computer.
2. Connecting one or more ACM/16, ACM/16RJ or ACM/Flex16 external modules.

You must configure the various settings before installing the Host Adapter in the computer. In order to insure a successful installation, please follow the steps in the order specified above.



*The NT960/PCI Host Adapter is very sensitive to static electricity. Make sure that before you remove the card from the anti-static shipping bag, you wear an anti-static wristband. When you remove the board from the anti-static bag, handle it only by the edges and place it on the anti-static bag or an anti-static mat.*

### Installing the NT960/PCI in your System

To install the NT960/PCI Host Adapter in your computer follow these steps:



*Computer components are very sensitive to static electricity. When installing adapters in your computer make sure that you wear an anti-static wristband. Handle the adapter by its edges and place it on the anti-static bag or an anti-static mat.*

1. Turn the power off to your computer.
2. Open your computer to expose the expansion slots (consult the system documentation for information on this procedure.)
3. Choose an available PCI expansion slot.
4. Remove the screw and the expansion slot cover from the slot you select and save both.
5. Place the NT960/PCI in the expansion slot and push down gently until the card seats fully in the slot.

**Note:** *Do not force the card into the expansion slot. If you meet a great deal of resistance, remove the board and try again.*

6. Align the mounting bracket and secure the board with the screw that you saved.
7. Close your computer.

### ACM/16, ACM/16RJ and ACM/Flex16

The installation of an ACM/16, ACM/16RJ or ACM/Flex16 external module consists of:

1. Setting the ACM/16, ACM/16RJ or ACM/Flex16 address number
2. Installing the Serial Line Interface Modules (SLIMs) in the ACM/Flex16
3. Connecting one or more ACM/16, ACM/16RJ or ACM/Flex16 modules to the NT960/PCI Host Adapter

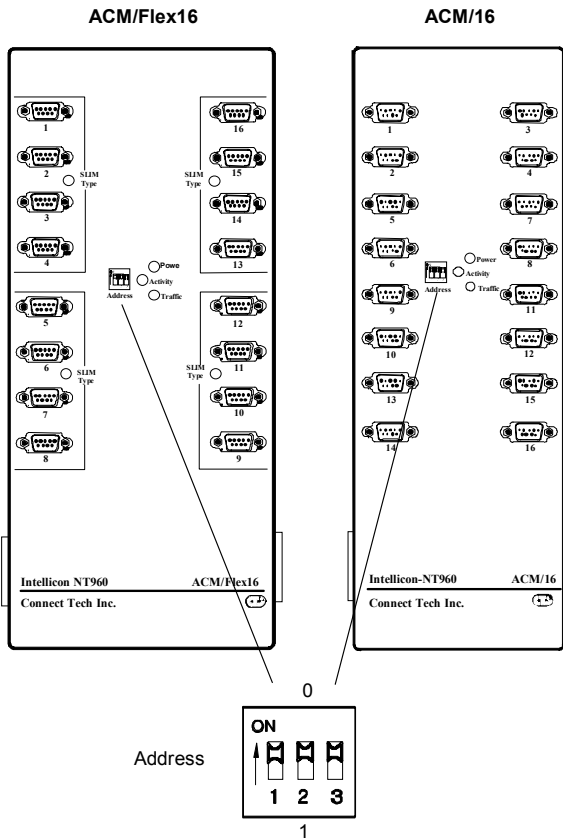
To insure a successful installation, you must configure the appropriate settings and follow the steps in the order specified.

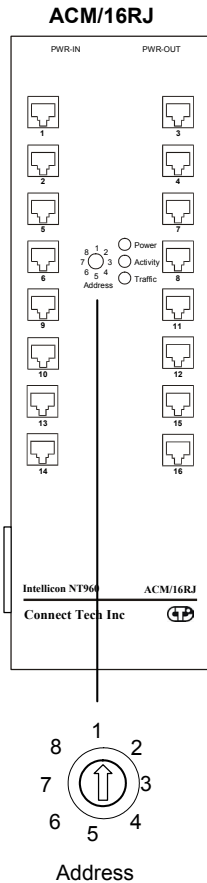


### ACM/16/16RJ/Flex16 Address Selection

The ACM/16, ACM/Flex16 and ACM/16RJ address switch block or switch assigns a number for each port on the ACM/16, ACM/16RJ and ACM/Flex16. This switch setting enables the Host Adapter to identify each port. You must set each ACM/16, ACM/Flex16 or ACM/16RJ connected to a NT960/PCI Host Adapter for an unique address. Please refer to **Figures 7 and 8** for the location and orientation of the ACM/16, ACM/Flex16 and ACM/16RJ address switch block or switch.

**Figure 7:** ACM/16/Flex16 address switch block



**Figure 8:** ACM/16RJ address switch block

The ACM/16, ACM/Flex16 and ACM/16RJ ship with the address switch block or switch set for address 1, which assigns numbers 1 through 16 to the serial ports. If you are connecting only one ACM/16, ACM/16RJ or ACM/Flex16 to the Host Adapter then use this setting. If you are connecting more than one then configure each ACM/16, ACM/16RJ or ACM/Flex16 with a unique address. **Table 1** outlines all the switch settings for the address switch block and their corresponding address and port numbers.

# WARNING

*Do not use a pencil to set the DIP switches as the lead graphite may short-circuit the switch.*

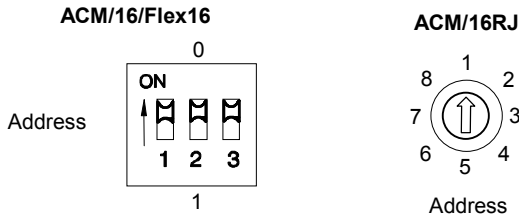
**Table 1: ACM/16/Flex16/16RJ address settings**

Address	Port numbers assigned	ACM/16RJ Switch settings	ACM/16/Flex16 DIP Switch settings		
			1	2	3
1	1 - 16	1	on	on	on
2	17 - 32	2	off	on	on
3	33 - 48	3	on	off	on
4	49 - 64	4	off	off	on
5	65 - 80	5	on	on	off
6	81 - 96	6	off	on	off
7	97 - 112	7	on	off	off
8	113 - 128	8	off	off	off

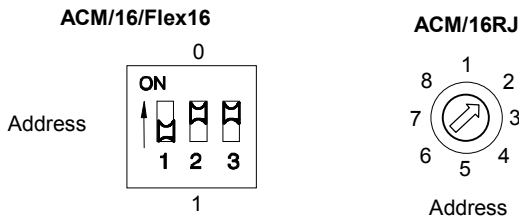
**Example:**

The following examples show the ACM/16, ACM/Flex16 or ACM/16RJ address switch block or switch set for:

*Address 1, ports 1 through 16(default):*



*Address 2, ports 17 through 32:*



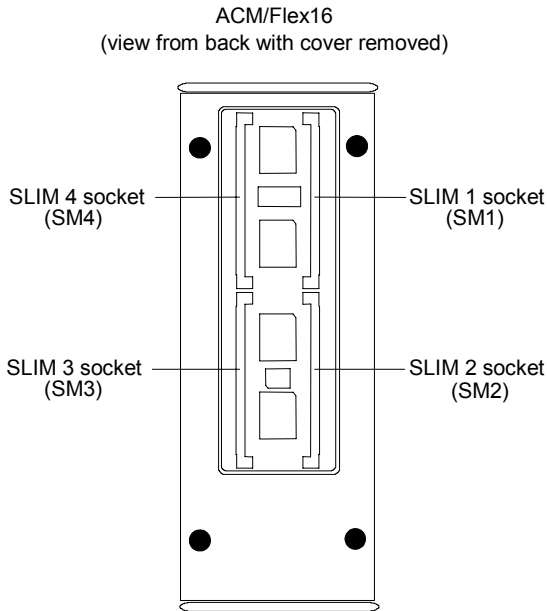
**SLIM Installation(ACM/Flex16)**

The ACM/Flex16 module has four 72 pin SLIM sockets that accept line transceiver modules. Each transceiver module provides the RS-232 or RS-485/422 or 20mA Current Loop receivers and transmitters to condition four serial ports. SLIM 1 interfaces ports 1, 2, 3, 4; SLIM 2 interfaces ports 5, 6, 7, 8; SLIM 3 interfaces ports 9, 10, 11, 12; and SLIM 4 interfaces ports 13, 14, 15, 16. Refer to **Figure 9** for the location and orientation of the SLIM sockets on the ACM/Flex16

---

**Figure 9:** *ACM/Flex16: SLIM socket locations*

---



To insert a SLIM into a connector follow these steps:

1. Place the SLIM into the socket almost vertically (about 75-degree angle), making sure that it is properly oriented and fully inserted into the socket.
2. Press downward and sideways on the SLIM until it latches into the socket. **Do NOT force the SLIM**, the installation process requires a small force and should be very smooth and easy. If you encounter resistance then re-check the orientation and insertion depth. Refer to **Appendix F: SLIM Insertion/Removal** regarding the removal of the ACM/Flex16 back cover and the insertion of a SLIM.

To remove a SLIM from a connector follow these steps:

1. Using both hands, place your thumbs on the metal clips that hold the SLIM into the socket, and place your index fingers on the edge of the SLIM.
2. Push outwards (with your thumbs) on the metal clips until the SLIM is released from the clips. Your index fingers can then raise the SLIM past the clips. The SLIM is then free to be removed from the ACM/Flex16 board. The force required to open the metal clips is small and the SLIM naturally springs upwards as soon as the clips are open wide enough. If removal is difficult, then you are probably trying to raise the SLIM before the clips are open. Refer to **Appendix F: SLIM Insertion/Removal** regarding the removal of the ACM/Flex16 back cover and the removal of a SLIM.



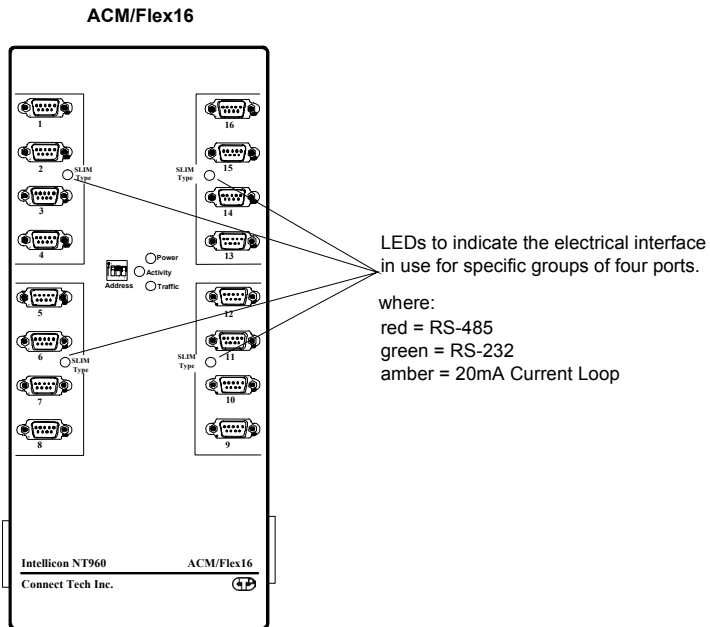
*The RS-232, RS-485/422 and 20mA Current Loop SLIMs are very sensitive to static electricity. Make sure that before you remove the SLIMs from the anti-static shipping bag, you wear an anti-static wristband. When you remove the board from the anti-static bag, handle it only by the edges and place it on the anti-static bag or an anti-static mat.*

**SLIM Options**

The ACM/Flex16 has four SLIM sockets to accept Connect Tech's RS-232 and/or RS-485/422 and/or 20mA Current Loop Serial Line Interface Modules (SLIM). If you order RS-232 modules please refer to **Appendix C: RS-232 Option** for more technical information. If you order RS-485/422 modules please refer to **Appendix D: RS-485/422 Option** for more technical information. If you order 20mA Current Loop modules please refer to **Appendix E: 20mA Current Loop Option** for more technical information.

**LED interface indicators (ACM/Flex16)**

You can install RS-232 and/or RS-485/422 and/or 20mA Current Loop Serial Line Interface Modules in your ACM/Flex 16. The ACM/Flex16 has LED indicators on its front panel to show you the electrical interface in use for a specific group of four ports. When the LED is red the RS-485/422 interface is in use; when it is green the RS-232 interface is in use; and when it is amber the 20mA Current Loop interface is in use. Please refer to **Figure 10** for the location of these LED interface indicators.

**Figure 10:** LED interface indicators (ACM/Flex16)


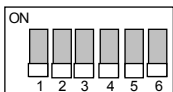
***Note:** The Serial Line Interface Modules control four ports, and therefore the LED indicators show the electrical interface in use for four ports.*

### ACM/16/16RJ/Flex16 to NT960/PCI Host Adapter

The NT960/PCI was designed to be compatible with existing ACM setups, as well as to improve the performance of these and other new installations. You can achieve this performance improvement by setting switch 6 on DIP switch block SW1 on the NT960/PCI Host Adapter and by using a new bus cable assembly. Please refer to **Figure 1** for the location of DIP switch block SW1.

The following table shows appropriate settings for DIP switch block SW1 for various ACM configurations.

**Table 2:** *NT960/PCI SW1 switch settings*

Switch Position	Configuration
 <p style="text-align: center;">SW1</p>	<p>Switch 6 on DIP switch block SW1 set <b>on</b>. One to 8 ACM modules stacked together, with only <b>one</b> bus cable between the NT960/PCI Host adapter and the first ACM module.</p>
 <p style="text-align: center;">SW1</p>	<p>Switch 6 on DIP switch block SW1 set <b>off</b>. Any number of ACM modules with <b>2</b> bus cables (one cable between the NT960/PCI Host adapter and the first ACM, and then another cable somewhere between the first ACM and last ACM).</p>

The steps to connect ACM/16, ACM/16RJ and ACM/Flex16 external modules to a NT960/PCI Host Adapter are:

1. Turn off or disconnect the power to the computer containing the NT960/PCI Host Adapter.
2. Connect the ACM/16, ACM/16RJ or ACM/Flex16 to the NT960/PCI Host Adapter with the DB37 bus cable supplied.
3. If you are connecting more than one ACM/16, ACM/16RJ or and/or ACM/Flex16 to the Host Adapter, verify that each module has a unique address switch setting.
4. The NT960/PCI Host Adapter can connect up to a maximum of eight ACM/16, ACM/16RJ and/or ACM/Flex16 modules giving you a total of 128 ports. You can connect the modules directly to each other. When connecting the modules to each other please attach metal straps between each module.
5. After you connect the ACM/16, ACM/16RJ and/or ACM/Flex16 modules to the Host Adapter and to each other, connect the ACM/16, ACM/16RJ or ACM/Flex16 power supply to the module and then plug it into your power source.



**Note:**

1. If an existing installation has a two cable configuration, we recommend that you replace the cables with the newer cable assembly.
2. You should use no more than two bus cables for the entire subsystem.

**Note:**

**The ACM/16 and ACM/16RJ require the connection of only one external power supply for every 48 ports connected to a HOST Adapter.** Please connect the power supply to the POWER IN connector on the first ACM/16 or ACM/16RJ module (16 ports) and then connect power cables between the POWER OUT and the POWER IN connectors on the ACM/16 or ACM/16RJ modules.

When you add another ACM/16 or ACM/16RJ module to bring the total to 64 ports you must connect another external NT960 power supply to the POWER IN connector on this additional ACM/16 or ACM/16RJ module. If you add another 32 ports to bring the total to 96 ports you can once again connect power cables between the POWER OUT and POWER IN connectors on the ACM/16 or ACM/16RJ modules. Please refer to **Figures 11, 12 and 13** for connecting multiple ACM/16, ACM/16RJ or ACM/Flex16 modules.

**Note:**

**The ACM/Flex16 with RS-232 and/or 20mA interfaces only requires the connection of one external power supply for every 48 ports connected to a HOST Adapter.**

**The ACM/Flex16 with RS-485 only or a combination of RS-232 and RS-485 and 20mA Current Loop interfaces requires the connection of one external power supply for every 32 ports connected to a HOST Adapter.**

Please connect the power supply to the POWER IN connector on the first ACM/Flex16 (or ACM/16/16RJ) module (16 ports) and then connect power cables between the POWER OUT and the POWER IN connectors on the ACM/16, ACM/16RJ and ACM/Flex16 modules.

When you add another ACM/Flex16 or ACM/16 or ACM/16RJ module to bring the total to 48 ports you must connect another external NT960 power supply to the POWER IN connector on this additional ACM/Flex16, ACM/16 or ACM/16RJ module. If you add another 16 ports to bring the total to 64 ports you can once again connect power cables between the POWER OUT and POWER IN connectors on the ACM/Flex16, ACM/16 or ACM/16RJ modules. Please refer to **Figures 11, 12 and 13** for connecting multiple ACM/16/16RJ/ modules.

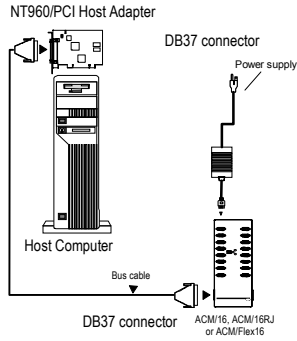
6. Turn on or connect the power to your host computer.

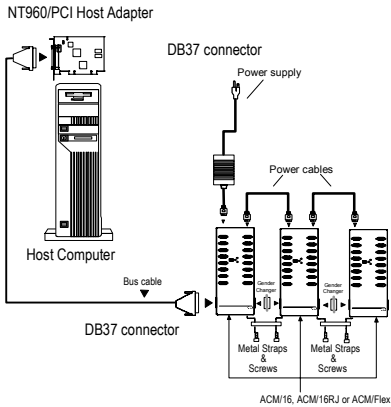
## WARNING

1. When connecting or disconnecting an ACM/16, ACM/16RJ or ACM/Flex16 to a NT960/PCI Host Adapter or to another ACM/16, ACM/16RJ or ACM/Flex16 module, **you must turn off or disconnect the computer's power supply and the power supply to the ACM/16, ACM/16RJ or ACM/Flex16 module(s). Failure to observe this precaution will result in damage to the NT960/PCI Host Adapter, ACM/16, ACM/16RJ or ACM/Flex16.**
2. You can connect only ACM/16, ACM/16RJ or ACM/Flex16 modules to a NT960/PCI Host Adapter or to another ACM/16, ACM/16RJ or ACM/Flex16 module. **Failure to observe this precaution will result in damage to the NT960/PCI Host Adapter, ACM/16, ACM/16RJ or ACM/Flex16.**

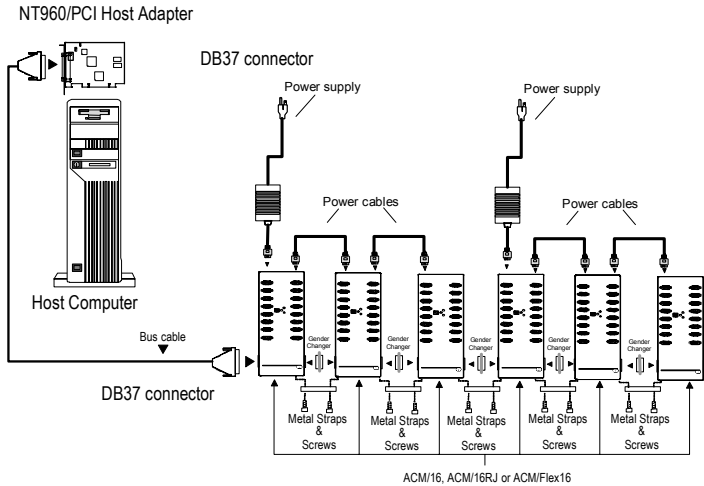
**Figures 11, 12 and 13** show different methods of connecting ACM/16, ACM/16RJ or ACM/Flex16 modules to the NT960/PCI Host Adapter.

**Figure 11:** *Connection of one ACM/16/16RJ/Flex16 module*



**Figure 12:** *Connection of three ACM/16/16RJ/Flex16 modules***Note:**

1. *The ACM/Flex16 with RS-232 and/or 20mA Current Loop interfaces only requires the connection of one external power supply for every 48 ports connected to a HOST Adapter.*
2. *The ACM/Flex16 with RS-485 only or a combination of RS-232 and RS-485 and 20mA Current Loop interfaces requires the connection of one external power supply for every 32 ports connected to a HOST Adapter.*
3. *Please install all the metal straps provided to insure a proper connection between ACM/16/16RJ/Flex16 modules. You should install these straps between both the top and the bottom of the ACM/16/16RJ/Flex16 modules. Failure to do so will cause an intermittent connection that will disrupt communications.*

**Figure 13:** Connection of six ACM/16/16RJ/Flex16 modules**Note:**

1. The ACM/Flex16 with RS-232 and/or 20mA Current Loop interfaces only requires the connection of one external power supply for every 48 ports connected to a HOST Adapter.
2. The ACM/Flex16 with RS-485 only or a combination of RS-232 and RS-485 and 20mA Current Loop interfaces requires the connection of one external power supply for every 32 ports connected to a HOST Adapter.
3. Please install all the metal straps provided to insure a proper connection between ACM/16/16RJ/Flex16 modules. You should install these straps between both the top and the bottom of the ACM/16/16RJ/Flex16 modules. Failure to do so will cause an intermittent connection that will disrupt communications.



# Chapter 3: Software Installation

---

Introduction ..... 3-1





## Introduction

Your Intellicon-NT960/PCI subsystem boards may ship with diskettes that include README files. Please examine these files for technical tips or release notes concerning installation and configuration of various device drivers and software utilities. If you require further information please contact Connect Tech Customer Support.

Before installing the Intellicon-NT960/PCI software device driver, verify and note your switch and jumper settings for:

- The ACM/16, ACM/16RJ and ACM/Flex16 module(s) address switch settings.

### ***Technical Tips:***

1. *Your NT960/PCI subsystem may ship with diskettes that include README files. Please examine these files for technical tips or release notes concerning installation and configuration of various device drivers and software utilities.*
2. *If you did not receive a driver diskette for your operating system or you require additional information, please go to the **Download Zone** of the **Support Center** on the *Connect Tech* website for product manuals, installation guides and device driver software.*



# Chapter 4: Appendices

---

Appendix A: Specifications.....	4-1
NT960/PCI Host Adapter.....	4-1
Processor .....	4-1
Memory .....	4-1
PCI Bus Interface .....	4-1
Operating Environment.....	4-1
Power Requirements.....	4-1
Dimensions.....	4-1
NT960/PCI ACM/16, ACM/16RJ, ACM/Flex16.....	4-1
Asynchronous Communication Module .....	4-1
Operating Environment .....	4-2
Power Requirements.....	4-2
Dimensions.....	4-2
NT960/PCI Part Numbers.....	4-3
Certification .....	4-4
Intellicon-NT960/PCI; ACM/16/Flex16/16RJ .....	4-4
FCC.....	4-4
DOC/IC.....	4-4
General .....	4-4
Appendix B: Connector Pinouts .....	4-5
ACM/16 Pinouts .....	4-5
ACM/Flex16 Pinouts .....	4-6
ACM/Flex16 SLIM Pinouts.....	4-6
ACM/16RJ Pinouts .....	4-9
Appendix C: RS-232 Option .....	4-10
Installation .....	4-11
LED interface indicators .....	4-11
Appendix D: RS-485/422 Option .....	4-12
Introduction.....	4-12
Installation .....	4-14
LED interface indicators .....	4-14
Configuration options .....	4-15
Line bias feature .....	4-17
Line load options .....	4-17
RS-485/422 Cable Wiring.....	4-20
Appendix E: 20mA Current Loop Option .....	4-22
Installation .....	4-23
LED interface indicators .....	4-23
20mA Current Loop.....	4-24
Current Loop Cable Wiring .....	4-25

Appendix F: SLIM Insertion/Removal .....	4-26
ACM/Flex16 back cover removal .....	4-27
SLIM insertion .....	4-28
SLIM removal .....	4-29
Appendix G: Factory Settings .....	4-30
NT960/PCI Host Adapter.....	4-30
ACM/16, ACM/Flex16, ACM/16RJ Modules .....	4-31
ACM/16, ACM/Flex16, ACM/16RJ Address Setting .....	4-31
ACM/Flex16: RS-485 SLIM options .....	4-34

## Appendix A: Specifications

### NT960/PCI Host Adapter

#### Processor

- Intel i960 JX™ 32 bit RISC processor, 33MHz

#### Memory

- 1MB of dual ported SRAM

#### PCI Bus Interface

- One 3.3V, 5V or Universal PCI slot
- Dual-ported RAM interface

#### Operating Environment

- Ambient temperature: 0 - 70 ° C
- Relative humidity: 0 - 90% no condensing
- Air movement: no requirement
- Altitude: 15,000 feet (5000 metres)

#### Power Requirements

- +3.3 vdc: 900 mA typical, 1.2 A maximum
- +5 vdc: 200 mA typical

#### Dimensions

- Length: 14.70 cm
- Height: 10.60 cm
- Width: 1.50 cm
- Weight: 0.10 kg

### NT960/PCI ACM/16, ACM/16RJ, ACM/Flex16

#### Asynchronous Communication Module

##### *ACM/16*

- Four CLCD1400 RISC like quad UARTs with 12 bytes of FIFO per channel on the chip
- EIA RS232-C Interface
- Sixteen RS-232 asynchronous ports with male DB-9 connectors
- Ports configurable from 50 up to 115 Kbps
- Programmable Baud Rate Generator

***ACM/Flex16***

- Four CLCD1400 RISC like quad UARTs with 12 bytes of FIFO per channel on the chip
- EIA RS232-C and/or RS485/422 Interface and/or 20mA Current Loop
- Sixteen RS-232 and/or RS-485/422 and/or 20mA Current Loop asynchronous ports with male DB-9 connectors
- Ports configurable from 50 up to 115 Kbps
- Programmable Baud Rate Generator

***ACM/16RJ***

- Four Cirrus Logic™ CD1400 RISC like quad UARTs with 24 bytes of FIFO per channel on the chip
- EIA RS232-C Interface
- Sixteen RS-232 asynchronous ports with RJ-45 connectors
- Ports configurable from 50 up to 115 Kbps
- Programmable Baud Rate Generator

**Operating Environment*****ACM/16, ACM/Flex16 and ACM/16RJ***

- Ambient temperature: 0 - 70 ° C
- Relative humidity: 0 - 90% no condensing
- Air movement: no requirement
- Altitude: 15,000 feet (5,000 metres)

**Power Requirements*****ACM/16, ACM/Flex16 and ACM/16RJ***

- Power supply provided

**Dimensions*****ACM/16***

- Length: 32.812 cm
- Width: 11.562 cm
- Height: 4.062 cm

***ACM/Flex16***

- Length: 32.812 cm
- Width: 14.100 cm
- Height: 4.062 cm

***ACM/16RJ***

- Length: 32.85 cm
- Width: 11.55 cm
- Height: 4.84 cm

**NT960/PCI Part Numbers**

NP001	Intellicon-NT960/PCI Host Adapter with 1MB of RAM.
NTACM16V2	Intellicon-NT960/PCI ACM/16 external module with DB-9 male connectors.
NTACM16V3	Intellicon-NT960/PCI ACM/16RJ external module with RJ-45 connectors.
NTACMF16	Intellicon-NT960/PCI ACM/Flex16 external module with DB-9 male connectors.
NT232SLM	ACM/Flex16 RS-232 SLIM.
NT485SLM	ACM/Flex16 RS-485 SLIM.
NT20MASLM	ACM/Flex16 20mA Current Loop SLIM
NTCAB	Intellicon-NT960/PCI bus cable, six feet long.
NTUPSLC	Intellicon-NT960/PCI ACM/16, ACM/16RJ or ACM/Flex16 external module power supply, 110 volts, with power line cord. (one power supply for every three modules)
NTPS220	Intellicon-NT960/PCI ACM/16, ACM/16RJ or ACM/Flex16 external module power supply, 220 volts, with no power line cord. (one power supply for every three modules)
NTACMPC	Intellicon-NT960/PCI ACM/16, ACM/16RJ or ACM/Flex16 power cable (only required to connect power between ACM modules).
CLIP001	Retaining clip for connecting ACM/16 modules, version 1, together.
CLIP002	Retaining clip for connecting ACM/16, version 2 modules, ACM/16RJ or ACM/Flex16 modules together.

## Certification

### Intellicon-NT960/PCI; ACM/16; ACM/Flex16; ACM/16RJ

#### FCC

This equipment complies with the requirements in Part 15 of FCC Rules for a Class A computing device. Operation of this equipment in a residential area may cause unacceptable interference to radio and TV reception requiring the operator to take whatever steps are necessary to correct the interference.

#### DOC/IC

This Class A digital apparatus meets all the requirements of the Canadian Interference-Causing Equipment Regulations as defined in ICES-003.

Cet appareil numérique de la classe A respecte toutes les exigences du Règlement sur le matériel brouiller du Canada.

#### General

The above agency conformances were met by independent laboratory testing of Connect Tech Inc. product(s) with shielded cables, with metal hoods, attached to either the terminating connectors or cable assemblies supplied with the product(s).

**Failure to follow good EMC/EMI compliant cabling practices may produce more emissions or less immunity than were obtained in laboratory measurements.**

Operation of this equipment in a residential area may cause unacceptable interference to radio a TV reception, requiring the user to take whatever steps necessary to correct the interference.



## Appendix B: Connector Pinouts

A cable with 37 pin connectors connects the Intellicon-NT960/PCI host adapter to an ACM/16, ACM/Flex16 or ACM/16RJ external module. ACM/16, ACM/Flex16 and ACM/16RJ modules also connect to each other via 37 pin connectors. These connections are a proprietary external bus interface not a serial interface, and therefore no pinouts are given for the 37 pin connectors.

### ACM/16 Pinouts

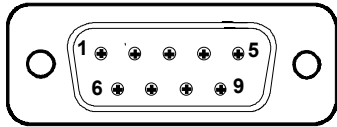
The ACM/16 provides male DB-9 connectors for each port. For the DB-9 pinout information please refer to **Table 3**.

**Table 3:** DB-9 pinouts - ACM/16

Pin No.	RS-232 Signal	Direction
1	DCD	input
2	RxD	input
3	TxD	output
4	DTR	output
5	SG	signal gnd.
6	DSR	input
7	RTS	output
8	CTS	input
9	RI	input

Male DB-9 Connector



The diagram shows a top-down view of a male DB-9 connector. It is a rectangular component with two circular mounting holes on the left and right sides. The connector has nine pins arranged in two rows. The top row contains pins 1, 2, 3, 4, and 5 from left to right. The bottom row contains pins 6, 7, 8, and 9 from left to right. The pins are numbered 1, 5, 6, and 9 in the diagram.

#### **Technical Tip:**

Please ensure that you terminate the DCD or CTS signals if your application does not use them. The common way to do this is to connect DCD to DTR and/or to connect CTS to RTS. Failure to do so may result in a loss of a performance on your Intellicon-NT960/PCI subsystem.

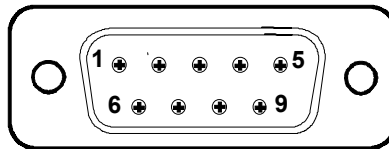
### ACM/Flex16 Pinouts

The ACM/Flex16 provides male DB-9 connectors for each port. For the DB-9 pinout information please refer to **Table 4**.

**Table 4:** DB-9 pinouts - ACM/Flex16

Pin No.	RS-232 Signal	Direction	RS-485 Signal	Direction	20mA Signal	Direction
1	DCD	input	RxD +	input	RxD -	input
2	RxD	input	TxD +	output	TxD +	output
3	TxD	output	TxD -	output	unused	
4	DTR	output	RxD -	input	unused	
5	SG	signal gnd.	SG	signal gnd.	unused	
6	DSR	input	CTS -	input	unused	
7	RTS	output	RTS -	output	TxD -	output
8	CTS	input	RTS +	output	RxD +	input
9	RI	input	CTS +	input	unused	

Male DB-9 Connector



**Note:** ports 3, 4, 7, 8, 11, 12, and 15 do not support the RI signal.

#### **Technical Tip:**

Please ensure that you terminate the DCD or CTS signals if your application does not use them. The common way to do this is to connect DCD to DTR and/or to connect CTS to RTS. Failure to do so may result in a loss of performance on your Intellicon-NT960/PCI subsystem.

### ACM/Flex16 SLIM Pinouts

You may order the ACM/Flex16 external module with RS-232, RS-485/422 and/or 20mA Current Loop Serial Line Interface Modules (SLIM). Please refer to **Table 5** for the pinouts for the SLIM sockets found on the ACM/Flex16 module.

**Table 5:** *ACM/Flex16 SLIM pinouts*

SLIM Pin No.	TTL Signal	RS-232 Signal	RS-485/422 Signal	Current Loop Signal
1	+12 V			
2	RxD 4			
3	TxD 4			
4	CTS 4			
5	RTS 4			
6	DSR 4			
7	DTR 4			
8	DCD 4			
9	+5 V			
10		DCD 4	RxD B(+) 4	RxD (-) 4
11		DSR 4	CTS A(-) 4	
12		RxD 4	TxD B(+) 4	TxD (+) 4
13		RTS 4	RTS A(-) 4	TxD (-) 4
14		TxD 4	TxD A(-) 4	
15		CTS 4	RTS B(+) 4	RxD (+) 4
16		DTR 4	RxD A(-) 4	
17		RI 4	CTS B(+) 4	
18		Ground	Signal ground	
19	RxD 3			
20	TxD 3			
21	CTS 3			
22	RTS 3			
23	DSR 3			
24	DTR 3			
25	DCD 3			
26	Reserved			
27	+5 V			
28		DCD 3	RxD B(+) 3	RxD (-) 3
29		DSR 3	CTS A(-) 3	
30		RxD 3	TxD B(+) 3	TxD (+) 3
31		RTS 3	RTS A(-) 3	TxD (-) 3
32		TxD 3	TxD A(-) 3	
33		CTS 3	RTS B(+) 3	RxD (+) 3
34		DTR 3	RxD A(-) 3	
35		RI 3	CTS B(+) 3	
36		Ground	Signal ground	

**Table 5(continued): ACM/Flex16 SLIM pinouts**

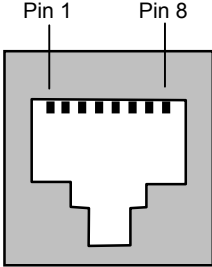
SLIM Pin No.	TTL Signal	RS-232 Signal	RS-485/422 Signal	Current Loop Signal
37	Ground			
38	RxD 2			
39	TxD 2			
40	CTS 2			
41	RTS 2			
42	DSR 2			
43	DTR 2			
44	DCD 2			
45	RI 2			
46		DCD 2	RxD B(+) 2	RxD (-) 2
47		DSR 2	CTS A(-) 2	
48		RxD 2	TxD B(+) 2	TxD (+) 2
49		RTS 2	RTS A(-) 2	TxD (-) 2
50		TxD 2	TxD A(-) 2	
51		CTS 2	RTS B(+) 2	RxD (+) 2
52		DTR 2	RxD A(-) 2	
53		RI 2	CTS B(+) 2	
54		Ground	Signal ground	
55	RxD 1			
56	TxD 1			
57	CTS 1			
58	RTS 1			
59	DSR 1			
60	DTR 1			
61	DCD 1			
62	RI 1			
63	-12 V			
64		DCD 1	RxD B(+) 1	RxD (-) 1
65		DSR 1	CTS A(-) 1	
66		RxD 1	TxD B(+) 1	TxD (+) 1
67		RTS 1	RTS A(-) 1	TxD (-) 1
68		TxD 1	TxD A(-) 1	
69		CTS 1	RTS B(+) 1	RxD (+) 1
70		DTR 1	RxD A(-) 1	
71		RI 1	CTS B(+) 1	
72		Ground	Signal ground	

### ACM/16RJ Pinouts

The ACM/16RJ provides RJ-45 modular connectors for each port. For the RJ-45 pinout information please refer to **Table 6**.

**Table 6:** *RJ-45 pinouts - ACM/16RJ*

Pin No.	RS-232 Signal	Direction
1	DCD	input
2	RTS	output
3	SR	
4	TxD	output
5	RxD	input
6	SR	
7	CTS	input
8	DTR	output

**Technical Tip:**

Please ensure that you terminate the DCD or CTS signals if your application does not use them. The common way to do this is to connect DCD to DTR and/or to connect CTS to RTS. Failure to do so may result in a loss of a performance on your Intellicon-NT960/PCI subsystem.

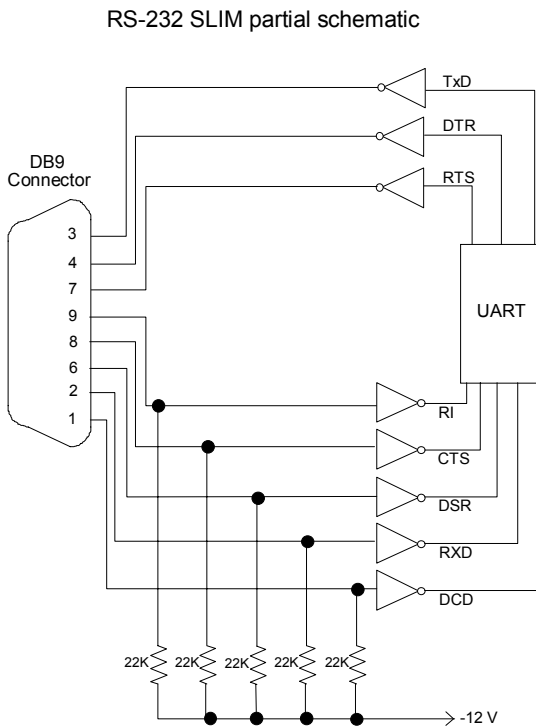
## Appendix C: RS-232 Option

You may order the ACM/Flex16 external module with RS-232 Serial Line Interface Modules (SLIM). The RS-232 SLIM offers the following features:

- Each SLIM controls four ports.
- LEDs on the ACM/Flex16 indicate the electrical interface in use for specific groups of four ports.
- SLIMS are field upgradeable, providing you with more flexibility for your application.

Please refer to **Figure 14** for a partial schematic of the RS-232 SLIM.

**Figure 14:** RS-232 SLIM partial schematic



**Note:** The RS-232 Serial Line Interface Module controls four ports, and therefore the schematic shows only a portion of the circuit.

## Installation

The ACM/Flex16 module has four 72 pin SLIM sockets which accept Serial Line Interface Modules. Each SLIM provides the RS-232 or RS-485/422 or 20mA Current Loop receivers and transmitters to condition four serial ports. SLIM 1 socket (SM1) interfaces ports 1, 2, 3, 4; SLIM 2 socket (SM2) interfaces ports 5, 6, 7, 8; SLIM 3 socket (SM3) interfaces ports 9, 10, 11, 12; and SLIM 4 socket (SM4) interfaces ports 13, 14, 15, 16. Please refer to **Figure 9** for the location of the SLIM sockets and to **Appendix F: SLIM Insertion/Removal** for the proper procedures to installing and removing SLIMs.



*Your ACM/Flex16 and Serial Line Interface Module (SLIM) are very sensitive to static electricity. Make sure that before you remove them from the anti-static shipping bag, you wear an anti-static wristband. When you remove them from the anti-static bag, handle them only by the edges and place them on the anti-static bag or an anti-static mat.*

## LED interface indicators

You can install RS-232 and/or RS-485/422 and/or 20mA Current Loop Serial Line Interface Modules in your ACM/Flex 16. The ACM/Flex16 has LED indicators on its front panel to show you the electrical interface in use for a specific group of four ports. When the LED is red the RS-485/422 interface is in use; when it is green the RS-232 interface is in use; and when it is amber the 20mA Current Loop interface is in use. Please refer to **Figure 10** for the location of these LED interface indicators.

## Appendix D: RS-485/422 Option

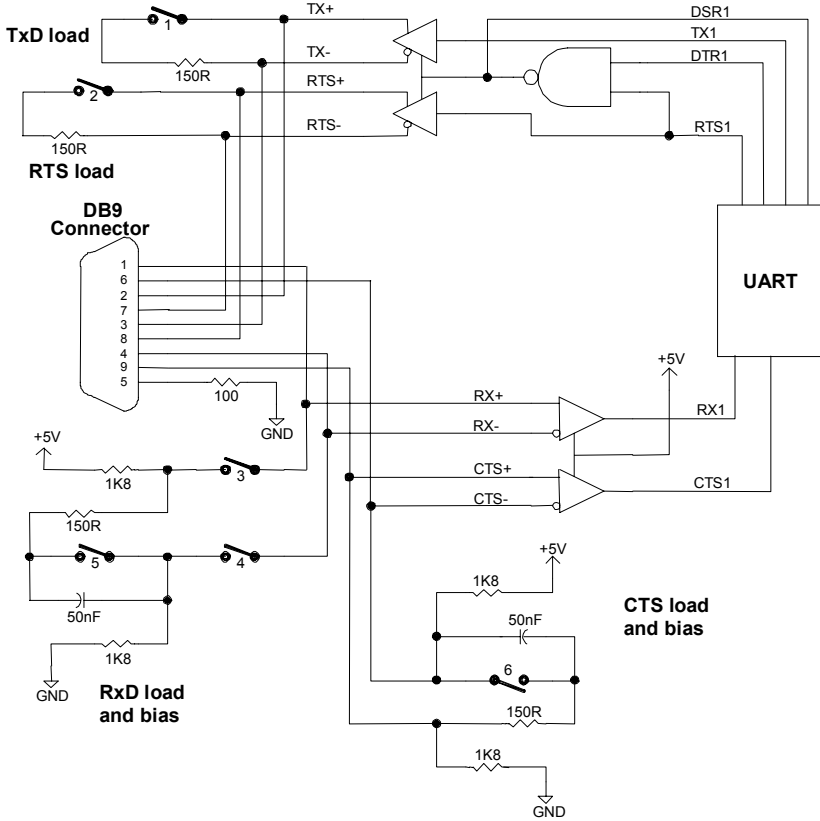
### Introduction

You may order the ACM/Flex16 external module with RS-485/422 Serial Line Interface Modules (SLIM). The RS-485/422 SLIM offers the following features:

- DIP switch selectable line load and bias options.
- Each SLIM controls four ports.
- LEDs on the ACM/Flex16 indicate the electrical interface in use for a specific group of four ports.
- SLIMs are field upgradeable, providing you with more flexibility for your application.

Please refer to **Figure 15** for a partial schematic of the RS-485/422 SLIM.



**Figure 15: RS-485/422 SLIM partial schematic****RS-485/422 SLIM partial schematic**

**Note:** The RS-485/422 Serial Line Interface Module controls four ports, and therefore the schematic shows only a portion of the circuit.

## Installation

The ACM/Flex16 module has four 72 pin SLIM sockets which accept Serial Line Interface Modules. Each SLIM provides the RS-232 or RS-485/422 or 20mA Current Loop receivers and transmitters to condition four serial ports. SLIM 1 socket (SM1) interfaces ports 1, 2, 3, 4; SLIM 2 socket (SM2) interfaces ports 5, 6, 7, 8; SLIM 3 socket (SM3) interfaces ports 9, 10, 11, 12; and SLIM 4 socket (SM4) interfaces ports 13, 14, 15, 16. Please refer to **Figure 9** for the location of the SLIM sockets and to **Appendix F: SLIM Insertion/Removal** for the proper procedures to installing and removing SLIMs.



*Your ACM/Flex16 and Serial Line Interface Module (SLIM) are very sensitive to static electricity. Make sure that before you remove them from the anti-static shipping bag, you wear an anti-static wristband. When you remove them from the anti-static bag, handle them only by the edges and place them on the anti-static bag or an anti-static mat.*

## LED interface indicators

You can install RS-232 and/or RS-485/422 and/or 20mA Current Loop Serial Line Interface Modules in your ACM/Flex 16. The ACM/Flex16 has LED indicators on its front panel to show you the electrical interface in use for a specific group of four ports. When the LED is red the RS-485/422 interface is in use; when it is green the RS-232 interface is in use; and when it is amber the 20mA Current Loop interface is in use. Please refer to **Figure 10** for the location of these LED interface indicators.

### Configuration options

The RS-485/422 SLIM on the ACM/Flex16 offers a wide range of features and configuration options. These features and options include:

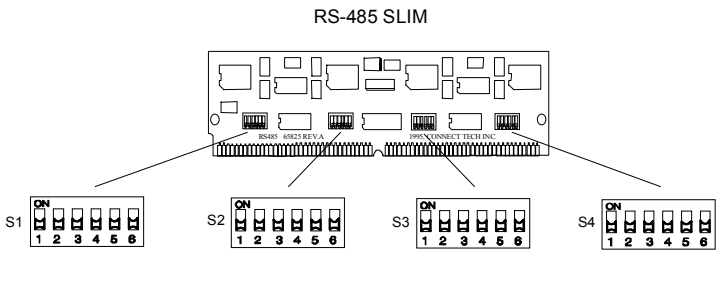
- Line bias features
- Line load options

You select these options and features by four (one for each port), 6 position DIP switches on the SLIM. Please refer to **Figure 16** for the locations of these DIP switches on the RS-485/422 SLIM. Please refer to **Table 7** for the port number/switch block relationship; and to **Table 8** for a summary of the line load options.

## WARNING

*Do not use a pencil to set the DIP switches as the lead graphite may short-circuit the switch.*

**Figure 16:** RS-485/422 SLIM - DIP switches



**Table 7:** RS-485/422 SLIM; port/switch block relation

Port number	SLIM socket	Switch block	Port number	SLIM socket	Switch block
1	SM1	S4	9	SM3	S4
2	SM1	S3	10	SM3	S3
3	SM1	S2	11	SM3	S2
4	SM1	S1	12	SM3	S1
5	SM2	S4	13	SM4	S4
6	SM2	S3	14	SM4	S3
7	SM2	S2	15	SM4	S2
8	SM2	S1	16	SM4	S1

**Table 8:** RS-485/422 SLIM; line load options

Switch Position	Configuration (when OFF)	Configuration (when ON)
1	TxD load is removed	TxD load enabled (150 ohms)
2	RTS load is removed	RTS load enabled (150 ohms)
3 & 4	RxD disconnected from bias and load circuits  <i>Note: These two switches MUST be used together</i>	RxD connected to bias and load circuits
5	RxD load is AC (150 ohms in series with 50 nF and > 50 metres in length)	RxD load is DC (150 ohms and < 50 metres in length)
6	CTS load is AC (150 ohms in series with 50 nF)	CTS load is DC (150 ohms)

**Technical Tip:** We recommend that you set the switches 3, 4 and 5 on the RS-485/422 SLIM to the **ON** (up) position for most RS-485 configurations.

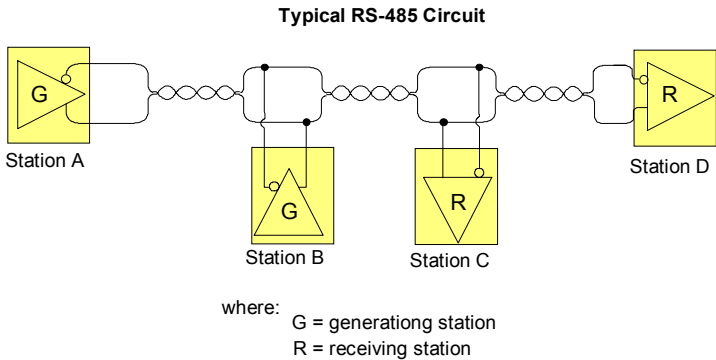
### Line bias feature

During the operation of a half duplex, or multi-drop RS-485/422 connection, there are situations (time intervals) when there is NO "generator station" driving the wires that interconnect the various stations. During these intervals the connection is susceptible to electrical interference from outside sources. The RS-485/422 SLIM has fixed bias circuits to reduce the sensitivity to electrical interference when no "generator station" (TxD and RTS) is driving the cable. These bias circuits force the "receiver stations" (RxD and CTS) into a known state.

### Line load options

RS-485/422 lines normally need some type of load to prevent an impedance mismatch that causes signal interference. The RS-485/422 specification defines line termination loads placed on either end of a twisted pair cable segment. Please refer to **Figure 17** as an example of a typical circuit for a RS-485 application.

**Figure 17:** Typical RS-485 circuit



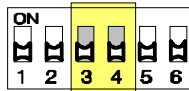
DIP switches S1, S2, S3, and S4 on the RS-485/422 SLIM allow you to select a "generator station" load and a "receiver station" load. The "generator station" is either the TxD or RTS signals. The "receiver station" is either the RxD or CTS signals.

The RS-485 SLIM also offers you the additional functionality to disconnect the RxD signal pair COMPLETELY from the load and bias circuits. This allows you to "multi-drop" the RxD station on a half duplex communication line. You select this option with switch positions 3 and 4 on switch blocks S1, S2, S3, and S4. Please refer to the following examples concerning this option and their switch settings.

**Examples:**

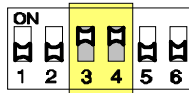
1. *The following example shows the RxD signal pairs on a ACM/Flex16 port disconnected from the load and bias circuits for multi-drop on a half duplex line.*

switch blocks  
S1, S2, S3, or S4



2. *The following example shows the RxD signal pairs on a ACM/Flex16 port connected to the load and bias circuits.*

switch blocks  
S1, S2, S3, or S4



Switch positions 1 and 2 on switch blocks S1, S2, S3 and S4 allow the "generator stations" (TxD and RTS) to have either no load or a **DC load** of 150 ohms. Please refer to the examples following for these configuration options and their switch settings.

Switch positions 5 and 6 on switch blocks S1, S2, S3, and S4 allow the "receiver stations" (RxD and CTS) to have either a **DC load** of 150 ohms or an **AC load** of 150 ohms in series with a 50 nF capacitor. Please refer to the examples following for these configuration options and their switch settings.

**Examples:**

1. The following example shows the switch settings for Station A as per **Figure 17** where TxD and RTS have a load of 150  $\Omega$ .

switch blocks  
S1, S2, S3, or S4



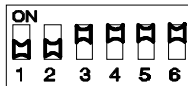
2. The following example shows the switch settings for Station B and Station C as per **Figure 17**.

switch blocks  
S1, S2, S3, or S4



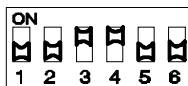
3. The following example shows the switch settings for Station D as per **Figure 17** where RxD and CTS have a DC load of 150  $\Omega$ .

switch blocks  
S1, S2, S3, or S4



4. The following example shows the switch settings for Station D as per **Figure 17** where the circuit is > than 50 metres in length and RxD and CTS have an AC load of 150  $\Omega$  in series with 50 nF.

switch blocks  
S1, S2, S3, or S4

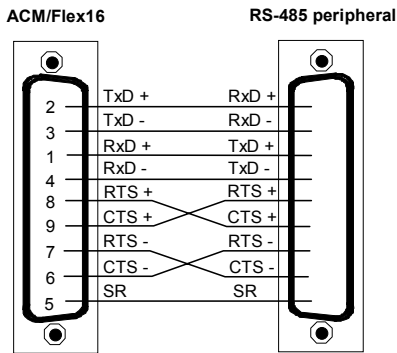


### RS-485/422 Cable Wiring

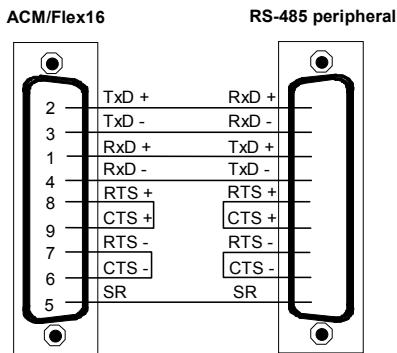
You can wire your ACM/Flex16 with the RS-485/422 option in various ways to communicate with RS-485/422 peripherals. This section will describe a few examples of RS-485/422 cabling schemes.

Figures 18, 19 and 20 describe 8 wire, 4 wire and 2 wire cabling schemes between a port on the ACM/Flex16 to a port on the RS-485/422 peripheral.

**Figure 18:** RS-485/422 wiring diagram(8 wire)

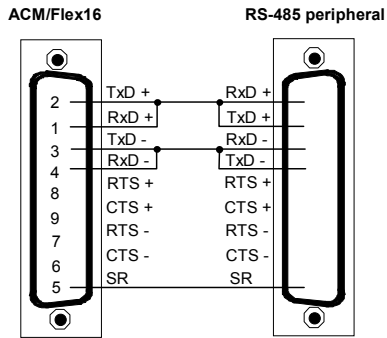


**Figure 19:** RS-485/422 wiring diagram(4 wire)





**Figure 20:** RS-485/422 wiring diagram(2 wire)



## Appendix E: 20mA Current Loop Option

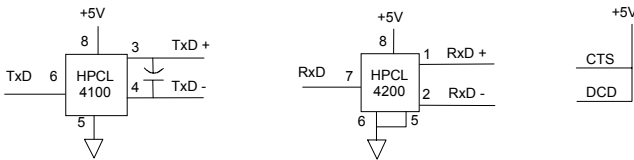
You may order the ACM/Flex16 with 20mA Current Loop Serial Line Interface Modules. ). The 20mA Current Loop SLIM offers the following features:

- A passive 20mA Current Loop electrical interface.
- The 20mA Current Loop receivers and transmitters are optically isolated.
- Each SLIM controls four ports.
- LEDs on the ACM/Flex16 indicate the electrical interface in use for a specific group of four ports.
- SLIMs are field upgradeable, providing you with more flexibility for your application.

Please refer to **Figure 21** for a partial schematic of the 20mA Current Loop SLIM.

**Figure 21:** 20mA Current Loop partial schematic

### 20mA Current Loop SLIM: partial schematic



**Note:** The 20mA Current Loop Serial Line Interface Module controls four ports, and therefore the schematic shows only a portion of the circuit.

## Installation

The ACM/Flex16 module has four 72 pin SLIM sockets which accept Serial Line Interface Modules. Each SLIM provides the RS-232 or RS-485/422 or 20mA Current Loop receivers and transmitters to condition four serial ports. SLIM 1 socket (SM1) interfaces ports 1, 2, 3, 4; SLIM 2 socket (SM2) interfaces ports 5, 6, 7, 8; SLIM 3 socket (SM3) interfaces ports 9, 10, 11, 12; and SLIM 4 socket (SM4) interfaces ports 13, 14, 15, 16. Please refer to **Figure 9** for the location of the SLIM sockets and to **Appendix F: SLIM Insertion/Removal** for the proper procedures to installing and removing SLIMs.



*Your ACM/Flex16 and Serial Line Interface Module (SLIM) are very sensitive to static electricity. Make sure that before you remove them from the anti-static shipping bag, you wear an anti-static wristband. When you remove them from the anti-static bag, handle them only by the edges and place them on the anti-static bag or an anti-static mat.*

## LED interface indicators

You can install RS-232 and/or RS-485/422 and/or 20mA Current Loop Serial Line Interface Modules in your ACM/Flex 16. The ACM/Flex16 has LED indicators on its front panel to show you the electrical interface in use for a specific group of four ports. When the LED is red the RS-485/422 interface is in use; when it is green the RS-232 interface is in use; and when it is amber the 20mA Current Loop interface is in use. Please refer to **Figure 10** for the location of these LED interface indicators.

## 20mA Current Loop

The 20mA Current Loop module provides optically isolated 20mA passive Current Loop interfaces for four ports. For each port there is an optically isolated receiver, and an optically isolated transmitter.

**Note:** Please refer to the Hewlett Packard Optoelectronics Manual/Catalogue for a complete description of HPCL 4100 and HPCL 4200 specifications.

To implement a passive interface, wire the transmitter and the receiver, to an external current source.

Please refer to **Figure 22** for a 20mA Current Loop cable wiring configuration between one port of a ACM/Flex16 and another port of an external device.

## WARNING

*There is a maximum loop resistance for a Current Loop circuit. The calculation for Maximum Loop Resistance( $R_L$ ) is:*

$$\text{Max } R_L = \frac{V_{OC} - (S \times V_D)}{0.020}$$

**Note:**

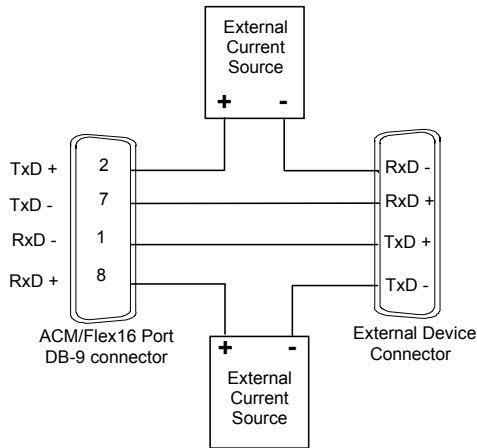
1.  $S$  = the number of stations in the loop (TX's and RX's).
2.  $V_D$  = the voltage drop for the HP opto couplers on the SLIM.  
 $V_D = 2.3 V$  for the HPCL 4100 and HPCL 4200. When you use other manufacturers' equipment in the loop the value of  $V_D$  may differ.
3.  $V_{OC}$  = the open circuit voltage of the current source.

### Current Loop Cable Wiring

You can wire the ACM/Flex16 with the 20mA Current Loop option in various ways to communicate with 20mA Current Loop peripherals. This section describes an example of a Current Loop cabling scheme.

**Figure 22** describes a 4 wire cabling scheme between a port on the ACM/Flex16 and another port on an external device.

**Figure 22:** *Current Loop wiring diagram(4 wire)*



**Note:**

*The example above illustrates a 20mA Current Loop cable wiring configuration between one port of the ACM/Flex16 and another port of an external device.*

## Appendix F: SLIM Insertion/Removal

This section outlines procedures for the following:

- ACM/Flex16 back cover removal.
- SLIM insertion.
- SLIM removal.



**ATTENTION**  
**Contents**  
**Static Sensitive**

*Your ACM/Flex16 and Serial Line Interface Module (SLIM) are very sensitive to static electricity. Make sure that before you remove them from the anti-static shipping bag, you wear an anti-static wristband. When you remove them from the anti-static bag, handle them only by the edges and place them on the anti-static bag or an anti-static mat.*

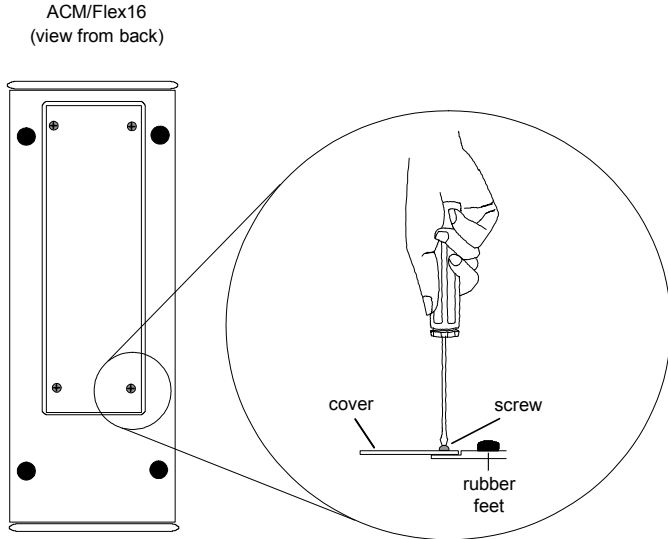
**ACM/Flex16 back cover removal**

**Figure 23** outlines the correct procedure for removing the back cover on the ACM/Flex16.

---

**Figure 23:** *ACM/Flex16 back cover removal*

---

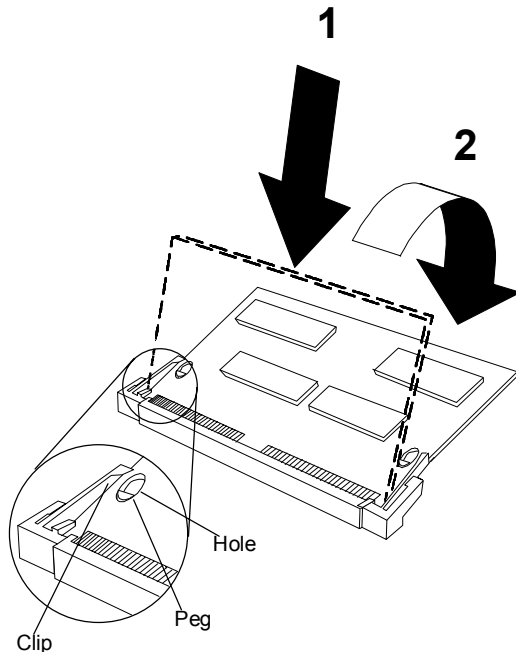
**ACM/Flex16 back cover removal**

1. To remove the cover on the back of the ACM/Flex16, unscrew the four screws on the back cover with the appropriate screwdriver.
-

**SLIM insertion**

**Figure 24** outlines the correct procedure for inserting an RS-232, RS-485/422 and 20mA Current Loop Serial Line Interface Module (SLIM).

**Figure 24:** *SLIM insertion (ACM/Flex16)*



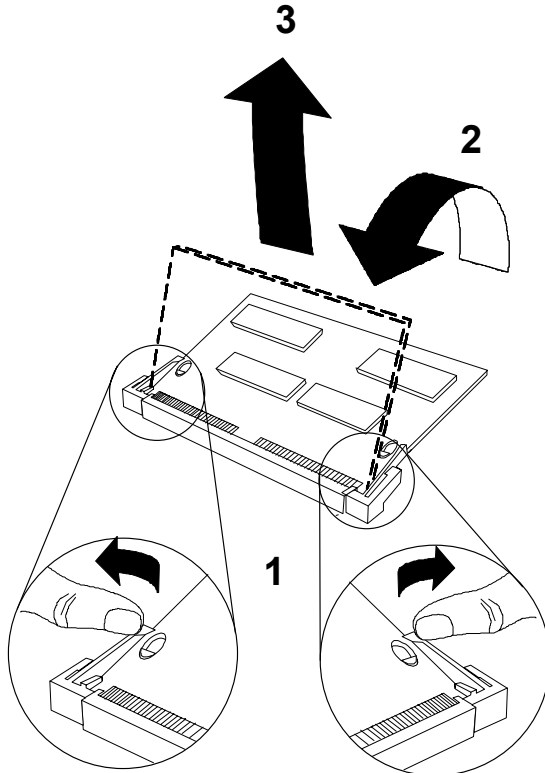
1. Place the SLIM into the socket almost vertically (about 75-degree angle), making sure that it is properly oriented and fully inserted into the socket.
2. Press downward and sideways on the SLIM until it latches into the socket. **Do NOT force the SLIM**, the installation process requires a small force and should be very smooth and easy. If you encounter resistance then re-check the orientation and insertion depth.



**SLIM removal**

**Figure 25** outlines the correct procedure for removing an RS-232, RS-485/422 and 20mA Current Loop Serial Line Interface Module (SLIM).

**Figure 25:** *SLIM removal(ACM/Flex16)*



1. Using both hands, place your thumbs on the clips that hold the SLIM into the socket, and place your index fingers on the edge of the SLIM.
2. Push outwards (with your thumbs) on the clips until the SLIM is released from the clips. Your index fingers can then raise the SLIM past the clips. The SLIM is then free to be removed from the ACM/Flex16 board. The force required to open the clips is small and the SLIM naturally springs upwards as soon as the clips are open wide enough. If removal is difficult, then you are probably trying to raise the SLIM before the clips are open.

## Appendix G: Factory Settings

This section summarizes the factory settings for the following Intellicon-NT960/PCI hardware components:

- Intellicon-NT960/PCI Host Adapter
- Intellicon-NT960/PCI ACM/16, ACM/16RJ and ACM/Flex16
- ACM/Flex16 RS-485 SLIM

### WARNING

*Do not use a pencil to set the DIP switches as the lead graphite may short-circuit the switch.*



*Your Intellicon-NT960/PCI adapter, ACM/Flex16 and Serial Line Interface Module (SLIM) are very sensitive to static electricity. Make sure that before you remove them from the anti-static shipping bag, you wear an anti-static wristband. When you remove them from the anti-static bag, handle them only by the edges and place them on the anti-static bag or an anti-static mat.*

### NT960/PCI Host Adapter

The NT960/PCI Host Adapter ships with factory settings for the following:

**Table 9:** *NT960/PCI SW1 factory settings*

Switch Position	Configuration
<p style="text-align: center;">SW1</p>	<p>Switch 6 on DIP switch block SW1 set <b>on</b>. One to 8 ACM modules stacked together, with only <b>one</b> bus cable between the NT960/PCI Host adapter and the first ACM module.</p>
<p><b>Note:</b> <i>Switches 1 through 5 are set off and must not be changed.</i></p>	

**ACM/16, ACM/Flex16, ACM/16RJ Modules**

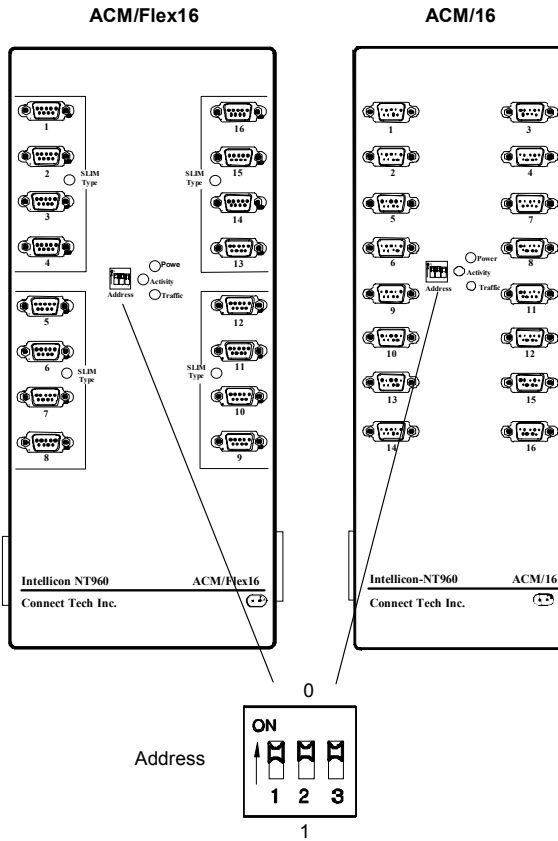
The NT960/PCI ACM/16, ACM/16RJ and ACM/Flex16 modules ship with factory settings for the following:

- ACM/16 ACM/16RJ, or ACM/Flex16 address
- ACM/Flex16: RS-485 SLIM options

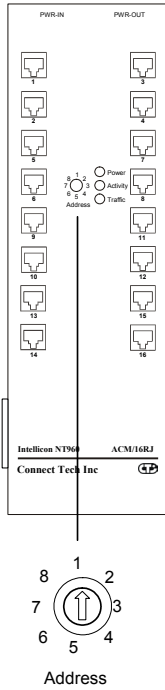
**ACM/16, ACM/Flex16, ACM/16RJ Address Setting**

The ACM/16, ACM/Flex16 or ACM/16RJ address switch block or switch assigns a number for each port on that particular ACM/16, ACM/Flex16 or ACM/16RJ. Connect Tech ships the ACM/16, ACM/Flex16 and ACM/16RJ with the address switch block or switch set for address 1. This setting assigns port numbers 1 through 16 to the serial ports on the ACM/16, ACM/Flex16 or ACM/16RJ module. **Figure 26** shows the location and factory setting of the ACM/16 and ACM/Flex16 address switch block. **Figure 27** shows the location and factory setting of the ACM/16RJ address switch.

**Figure 26:** *ACM/16, ACM/Flex16 factory settings*



**Figure 27:** ACM/16RJ factory setting



### ACM/Flex16: RS-485 SLIM options

The RS-485 SLIM for the ACM/Flex16 offers a wide range of configuration options. These options allow you to choose the line loads (DC or AC) and biasing for each port. DIP switch blocks S1, S2, S3, and S4 control these options. Connect Tech ships the RS-485 SLIM with all DIP switches set to the “OFF” position. **Figure 28** shows the location and the default factory settings for these DIP switches.

**Figure 28** shows the location and the default factory settings for these DIP switches.

**Figure 28:** *ACM/Flex16 RS-485 SLIM settings*

